

UPRIGHT ROCHESTER GAS



Product Features

The Upright Rochester is a traditional heritage post top lantern which has clear glazing. The lantern is hand crafted in aluminium with a highly decorative upright bracketry which connects the lantern to the control box.

Features

The Upright Rochester is manufactured from a collection of castings and spinings that come together to make this unique post top combination. The lantern is widely used throughout Covent Garden, the theatre District in London and also the Central District in Hong Kong

Controls

The permanent pilot and solenoid are mounted in the cast aluminium body of the lantern. If mains power is not present the optional battery powered Sugg Opto/clock offers timed control from a remote box fitted in the column base, also available a photocell operation from a remote location. Both control options are available for the Upright Rochester, for natural and LPG gases.

Options

The lantern is finished in Black RAL 9005 Powder coating as standard, other colours are available upon request but this may be subject to quantity.

Typical Specification

The Upright Rochester IP 54 lantern: manufactured from cast and spun aluminium, **stove painted Black RAL 9005 with clear glass** glazing, complete with a drop down brim and glass for access to the burners for maintenance. The Upright Rochester measures 700mm in height, and 435mm in diameter. Supplied with a powder coated galvanised inverted U bracket with decorative scrolls and a cast aluminium control box to fit a 76mm spigot. The Upright Rochester is fitted with a **6 light inverted** mantle superheated burner with integral solenoid and pilot.

Please note that items highlighted in bold can be changed using the options available.



Sugg Lighting Limited

Sussex Manor Business Park

Gatwick Road

Crawley

West Sussex

RH10 9GD

England



2004

Telephone: +44 (0)1293 540 111

Fax: +44 (0)1293 540 114

E-mail: sales@sugglighting.co.uk

www.sugglighting.co.uk

BURNER OPTIONS	SUPERHEATED CLUSTERS				
Key	Single	Double	Treble	Quad	Six
Upright Rochester	✓	✓	✓	✓	✓

FISHTAIL BURNER		
Single	Double	Treble
✓	✓	✓

GLAZING OPTIONS	
Glass Only	✓

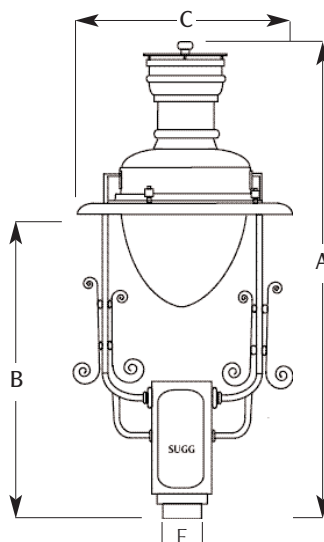

Fishtail Burners

The fishtail burner is a flat flame that is produced from a ceramic jet that ensures the flame is stable while providing the visual fishtail shape. This is sometimes referred to as a batwing burner and is preferred when the flame shape and appearance is of more importance than the light output.

DIMENSIONS	LANTERN	BOXED
A Lantern Height	680mm	970mm
B Lamp Height	360mm	780mm
C Diameter/Width	590mm	780mm
E Standard Entry	76mm	
Windage Area	0.157m ²	0.59m ³
Weight	11kg	20kg

© Sugg Lighting reserve the right to change the construction of their products without prior consultation. This ensures that product developments and continued improvements are maintained.